

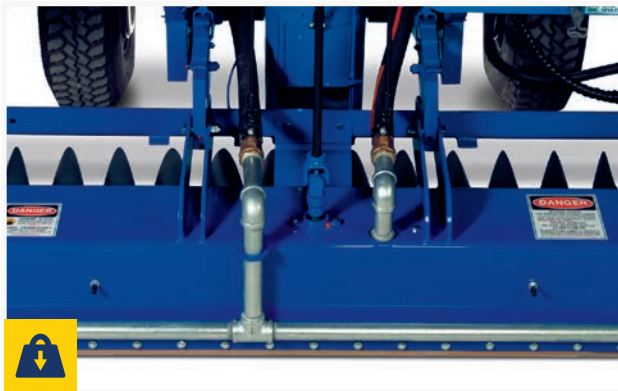

## POWER WITH EXCEPTIONAL MANEUVERABILITY

The powerful high-output compact engine introduces a new era of fuel efficiency, providing significant savings and a cleaner arena environment.

**MODEL  
446**



## POWER AND EFFICIENCY

The compact 2.4 L engine can be configured for gasoline, propane or CNG. On-board diagnostics with programmed oil change and maintenance intervals.



## TRANSMISSION

Continuously variable hydrostatic pump and motor are axial-piston type, providing superior on-ice power with maximum drawbar pull. Full hydrodynamic braking.



## DRIVETRAIN

Four-wheel drive. Rugged Dana Spicer® axles combine with an innovative hydrostatic transmission, providing the most reliable drivetrain in the industry.



## HYDRAULICS

Efficient double pump delivers full power and speed to the augers, even while the machine slows for corners. Easy access to high quality, low maintenance filters.



## CONSTRUCTION

Robust hand-welded steel tubing chassis. Premium primer/paint and rust-free poly ice-making water tank for corrosion resistance in the harsh environment it will call home.



## GLOBAL SERVICE AND SUPPORT

Zamboni Customer Service and a network of Zamboni Authorized Distributors provide exceptional and accessible service and support worldwide.

# ZAMBONI®

[zamboni.com](http://zamboni.com)

ZAMBONI and the configuration of the Zamboni® ice resurfacing machine are registered trademarks of Frank J. Zamboni & Co., Inc.  
© Zamboni 2016

 Reduced fuel consumption without compromise of performance

 Ease of operation with familiar automobile style controls and gauges

 Exceptional results from our unrivaled down pressure system

# MODEL 446

This brochure has been prepared only as a general guide for the customer. Every effort has been made to assure that the information presented is correct. Some features described or shown may be optional at extra cost. Prices, colors, materials, specifications and models are subject to change. For current product information, please contact the Zamboni Company.

# MODEL 446

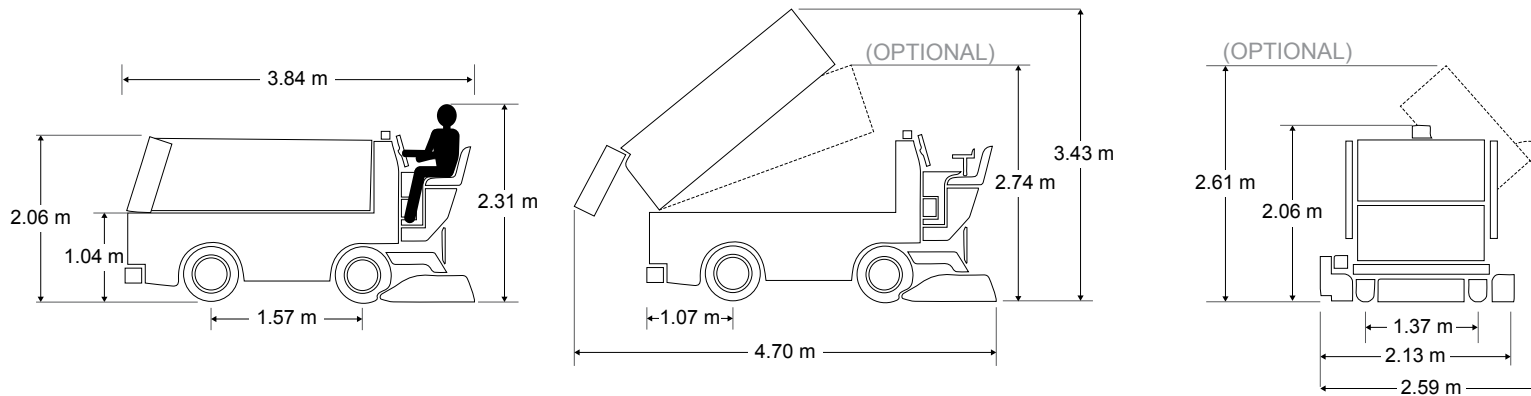

## CAPACITIES

### Snow Tank

Actual Volume	2.66 m <sup>3</sup>	94 cu. ft.
Compacted	3.17 m <sup>3</sup>	122 cu. ft.

### Water

Ice Making	627 L	166 gal.
Wash Water	218 L	58 gal.
Total	845 L	224 gal.

<b>Hydraulic Oil</b>	72 L	19 gal.
----------------------	------	---------

## POWERTRAIN

Four-Wheel Drive	
Engine	Mitsubishi® 2.4 L / 59 HP at 2500 RPM Four Cylinder Liquid Cooled
Transmission	Continuously variable hydrostatic pump and motor are axial-piston type.
Hydraulics	Powerful single pump for the vertical and horizontal augers. Hydraulic down pressure for optimal resurfacing results.

## Axles

Front	1950 kg	4300 lb
Rear	2177 kg	6400 lb

<b>Brakes</b>	Full Hydrodynamic Braking
---------------	---------------------------

## DIMENSIONS

### Overall

	L	W	H	L	W	H
Snow Tank Down	3.84 m	2.13 m	2.06 m	151 in.	84 in.	81 in.
Snow Tank Up	4.70 m	2.13 m	3.43 m	185 in.	84 in.	135 in.

### Shaving Blade

	L	W	H	L	W	H
	195.6 cm	12.7 cm	1.27 cm	77 in.	5 in.	0.5 in.

### Clearance

Minimum Operator Height Clearance	2.31 m	91 in.
Snow Pit Clearance	104.1 cm	41 in.

### Conveyor System

Horizontal Auger Diameter	25.4 cm	10 in.
Vertical Auger Diameter	25.4 cm	10 in.

### Manueverability

Wheelbase	1.57 m	62 in.
Wheel Track	1.37 m	54 in.
Turning Radius at Conditioner	4.57 m	15 ft.

## Weight

Empty	2660 kg	5860 lb
with Water	3502 kg	7720 lb